

Turbo Tech 101 | Basic: Understanding the Parts of the Turbocharger

Garrett
ADVANCING MOTION

www.garrettmotion.com

Engine power is proportional to the amount of air and fuel that can get into the cylinders. All things being equal, larger engines flow more air and as such will produce more power. If we want our small engine to perform like a big engine, or simply make our bigger engine produce more power, our ultimate objective is to draw more air into the cylinder. By installing a Garrett turbocharger, the power and performance of an engine can be dramatically increased.

So how does a turbocharger get more air into the engine?
Let us first look at the schematic below:

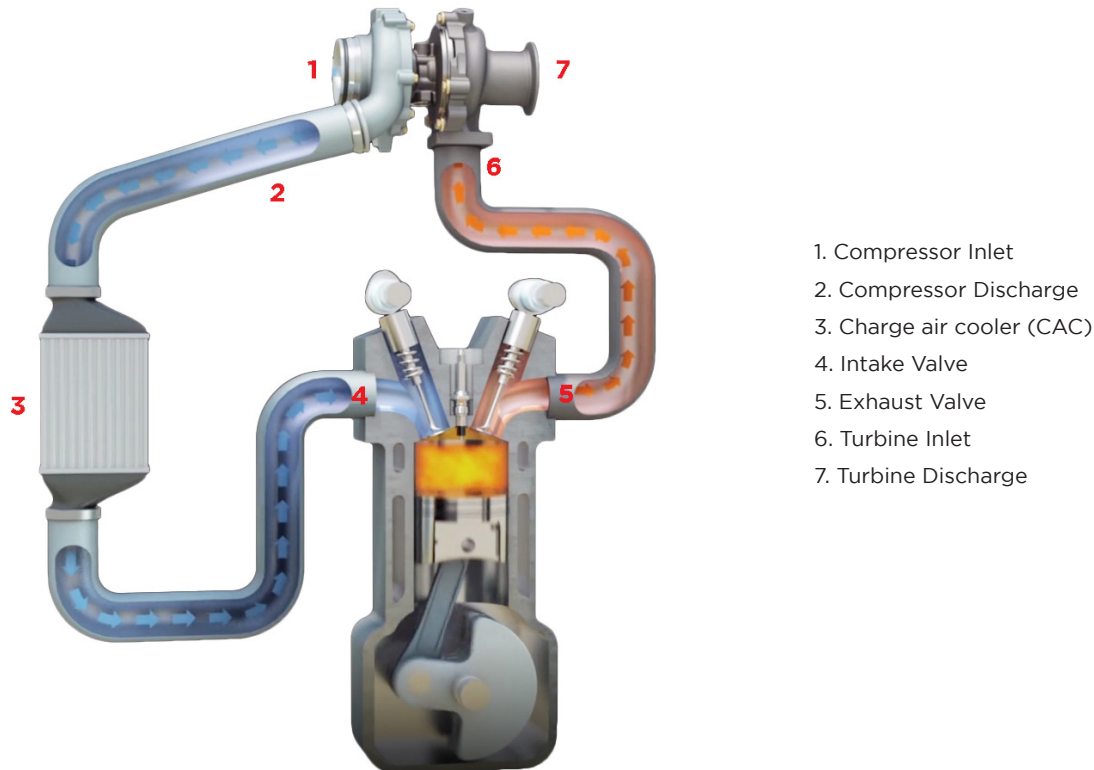

1. Compressor Inlet
2. Compressor Discharge
3. Charge air cooler (CAC)
4. Intake Valve
5. Exhaust Valve
6. Turbine Inlet
7. Turbine Discharge

The components that make up a typical turcharger system are:

- The air filter (not shown) through which ambient air passes before entering the compressor (1)
- The air is then compressed which raises the air's density (mass / unit volume) (2)
- Many turbocharged engines have a charge air cooler (aka intercooler) (3) that cools the compressed air to further increase its density and to increase resistance to detonation
- After passing through the intake manifold (4), the air enters the engine's cylinders, which contain a fixed volume. Since the air is at elevated density, each cylinder can draw in an increased mass flow rate of air. Higher air mass flow rate allows a higher fuel flow rate (with similar air/fuel ratio). Combusting more fuel results in more power being produced for a given size or displacement.

- After the fuel is burned in the cylinder it is exhausted during the cylinder's exhaust stroke in to the exhaust manifold (5)
- The high temperature gas then continues on to the turbine (6). The turbine creates backpressure on the engine which means engine exhaust pressure is higher than atmospheric pressure
- A pressure and temperature drop occurs (expansion) across the turbine (7), which harnesses the exhaust gas' energy to provide the power necessary to drive the compressor

What are the components of a turbocharger?

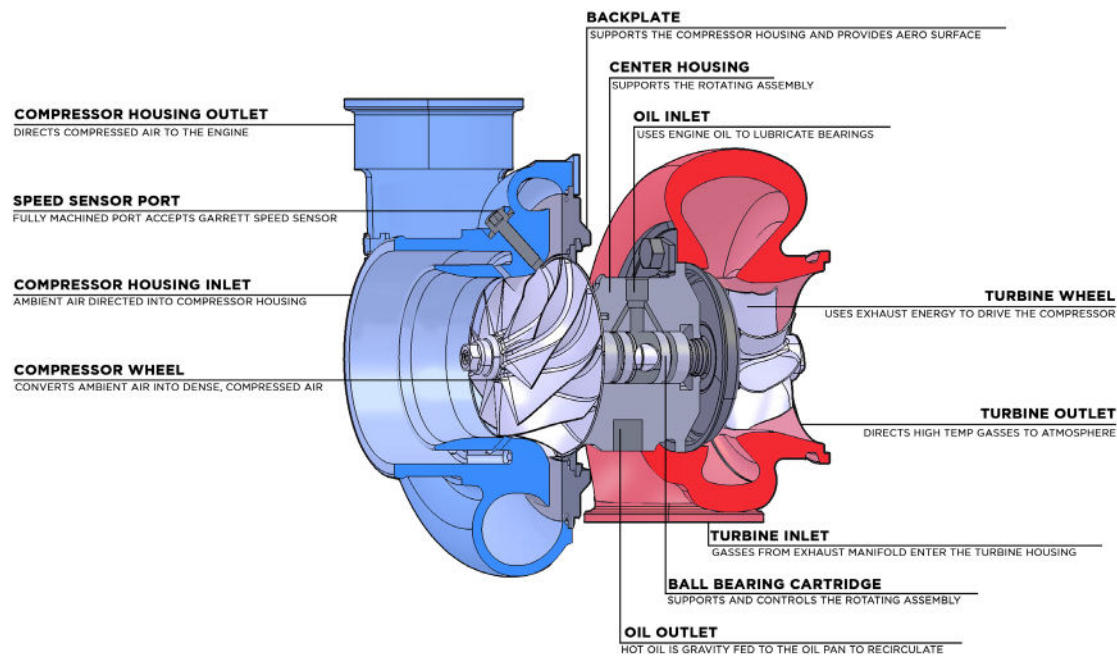

The layout of the turbocharger in a given application is critical to a properly performing system. Intake and exhaust plumbing is often driven primarily by packaging constraints. We will explore exhaust manifolds in more detail in subsequent tutorials; however, it is important to understand the need for a compressor bypass valve (commonly referred to as a Blow-Off valve) on the intake tract and a Wastegates for the exhaust flow.

Other Components

Blow-Off (Bypass) Valves

The Blow-Off valve (BOV) is a pressure relief device on the intake tract to prevent the turbo's compressor from going into surge. The BOV should be installed between the compressor discharge and the throttle body, preferably downstream of the charge air cooler (if equipped). When the throttle is closed rapidly, the airflow is quickly reduced, causing flow instability and pressure fluctuations. These rapidly cycling pressure fluctuations are the audible evidence of surge. Surge can eventually lead to thrust bearing failure due to the high loads associated with it.

Blow-Off valves use a combination of manifold pressure signal and spring force to detect when the throttle is closed. When the throttle is closed rapidly, the BOV vents boost in the intake tract to atmosphere to relieve the pressure; helping to eliminate the phenomenon of surge.



Wastegates

On the exhaust side, a Wastegates provides us a means to control the boost pressure of the engine. Some commercial diesel applications do not use a Wastegates at all. This type of system is called a free-floating turbocharger.

However, the vast majority of gasoline performance applications require a Wastegates. There are two (2) configurations of Wastegates, **internal** or **external**. Both internal and external Wastegates provide a means to bypass exhaust flow from the turbine wheel. Bypassing this energy (e.g. exhaust flow) reduces the power driving the turbine wheel to match the power required for a given boost level. Similar to the BOV, the Wastegates uses boost pressure and spring force to regulate the flow bypassing the turbine.

Internal Wastegates are built into the turbine housing and consist of a “flapper” valve, crank arm, rod end, and pneumatic actuator. It is important to connect this actuator only to boost pressure; i.e. it is not designed to handle vacuum and as such should not be referenced to an intake manifold.



External Wastegates are added to the exhaust plumbing on the exhaust manifold or header. The advantage of external Wastegates is that the bypassed flow can be reintroduced into the exhaust stream further downstream of the turbine. This tends to improve the turbine's performance. On racing applications, this Wastegated exhaust flow can be vented directly to atmosphere.

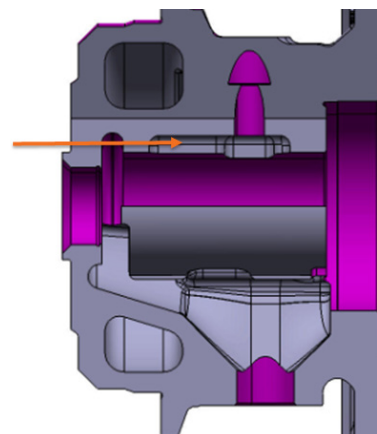

Oil & Water Plumbing

The intake and exhaust plumbing often receives the focus leaving the oil and water plumbing neglected.

Garrett ball bearing turbochargers require less oil than journal bearing turbos. Therefore an oil inlet restrictor is recommended if you have oil pressure over about 60 psig. The oil outlet should be plumbed to the oil pan above the oil level (for wet sump systems). Since the oil drain is gravity fed, it is important that the oil outlet points downward, and that the drain tube does not become horizontal or go “uphill” at any point.

Following a hot shutdown of a turbocharger, heat soak begins. This means that the heat in the head, exhaust manifold, and turbine housing finds its way to the turbo’s center housing, raising its temperature. These extreme temperatures in the center housing can result in oil coking.

To minimize the effects of heat soak-back, water-cooled center housings were introduced. These use coolant from the engine to act as a heat sink after engine shutdown, preventing the oil from coking. The water lines utilize a thermal siphon effect to reduce the peak heat soak-back temperature after key-off. The layout of the pipes should minimize peaks and troughs with the (cool) water inlet on the low side. To help this along, it is advantageous to tilt the turbocharger about 25° about the axis of shaft rotation.

Many Garrett turbos are water-cooled for enhanced durability.

Which Turbocharger is Right for Me or more affectionately known as My Turbo & Me

Selecting the proper turbocharger for your specific application requires many inputs. With decades of collective turbocharging experience, the Garrett Performance Distributors can assist in selecting the right turbocharger for your application.

The primary input in determining which turbocharger is appropriate is to have a target horsepower in mind. This should be as realistic as possible for the application. Remember that engine power is generally proportional to air and fuel flow. Thus, once you have a target power level identified, you begin to hone in on the turbocharger size, which is highly dependent on airflow requirements.

Other important factors include the type of application. An autocross car, for example, requires rapid boost response. A smaller turbocharger or smaller turbine housing would be most suitable for this application. While this will trade off ultimate power due to increased exhaust backpressure at higher engine speeds, boost response of the small turbo will be excellent.

Alternatively, on a car dedicated to track days, peak horsepower is a higher priority than low-end torque. Plus, engine speeds tend to be consistently higher. Here, a larger turbocharger or turbine housing will provide reduced backpressure but less-immediate low-end response. This is a welcome tradeoff given the intended operating conditions.

Selecting the turbocharger for your application goes beyond “how much boost” you want to run. Defining your target power level and the primary use for the application are the first steps in enabling your Garrett Performance Distributor to select the right turbocharger for you.

Journal Bearings vs. Ball Bearings

The journal bearing has long been the brawn of the turbocharger, however a ball-bearing cartridge is now an affordable technology advancement that provides significant performance improvements to the turbocharger.

Ball bearing innovation began as a result of work with the Garrett Motorsports group for several racing series where it received the term the ‘cartridge ball bearing’. The cartridge is a single sleeve system that contains a set of angular contact ball bearings on either end, whereas the traditional bearing system contains a set of journal bearings and a thrust bearing.



Journal Bearings



Ball Bearings

Turbo Response – When driving a vehicle with the cartridge ball bearing turbocharger, you will find exceptionally crisp and strong throttle response. Garrett Ball Bearing turbochargers spool up 15% faster than traditional journal bearings. This produces an improved response that can be converted to quicker 0-60 mph speed. In fact, some professional drivers of Garrett ball-bearing turbocharged engines report that they feel like they are driving a big, normally aspirated engine.

Tests run on CART turbos have shown that ball-bearings have up to half of the power consumption of traditional bearings. The result is faster time to boost which translates into better drivability and acceleration.

On-engine performance is also better in the steady-state for the Garrett Cartridge Ball Bearing.

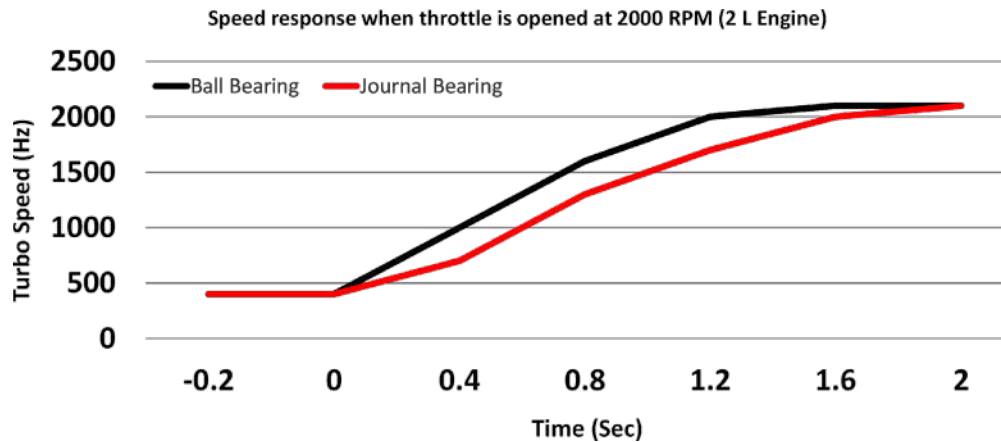

Reduced Oil Flow - The ball bearing design reduces the required amount of oil required to provide adequate lubrication. This lower oil volume reduces the chance for seal leakage. Also, the ball bearing is more tolerant of marginal lube conditions, and diminishes the possibility of turbocharger failure on engine shut down.

Improved Rotordynamics and Durability - The ball bearing cartridge gives better damping and control over shaft motion, allowing enhanced reliability for both everyday and extreme driving conditions. In addition, the opposed angular contact bearing cartridge eliminates the need for the thrust bearing commonly a weak link in the turbo bearing system.

Competitor Ball Bearing Options - Another option one will find is a hybrid ball bearing. This consists of replacing only the compressor side journal bearing with a single angular contact ball bearing. Since the single bearing can only take thrust in one direction, a thrust bearing is still necessary and drag in the turbine side journal bearing is unchanged. With the Garrett ball bearing cartridge the rotor-group is entirely supported by the ball bearings, maximizing efficiency, performance, and durability.

Ball Bearings in Original Equipment - Pumping up the MAZDASPEED Protegé's heart rate is a Garrett T25 turbocharger system. With Garrett technology on board, the vehicle gains increased acceleration without sacrificing overall efficiency and it has received many rave reviews from the world's top automotive press for it's unprecedented performance.

COMPETITION IS IN OUR NATURE

And so are the races we've won,
the records we've broken, and
our Motorsport partnerships.



Turbo
Technology



Electric &
Hybrid



Connected
Vehicles

Garrett
ADVANCING MOTION